

A ISO 5211 (Part I & II) Mounting Pad
Designed for universal adaptation of pneumatic or electric actuators, gear operators and handles.

B O-Ring
Secondary shaft seal.

C Name Plate
Permanently attached to body providing disc, seat and shaft material identification.

D Bushings
Four (4) bushings are used to provide maximum shaft support and centralized alignment of the one-piece shaft.

E Body
Available in full lug and wafer style.

F One-piece thru-shaft
The blow-out proof shaft design delivers positive disc-to-seat location while offering maximum strength.

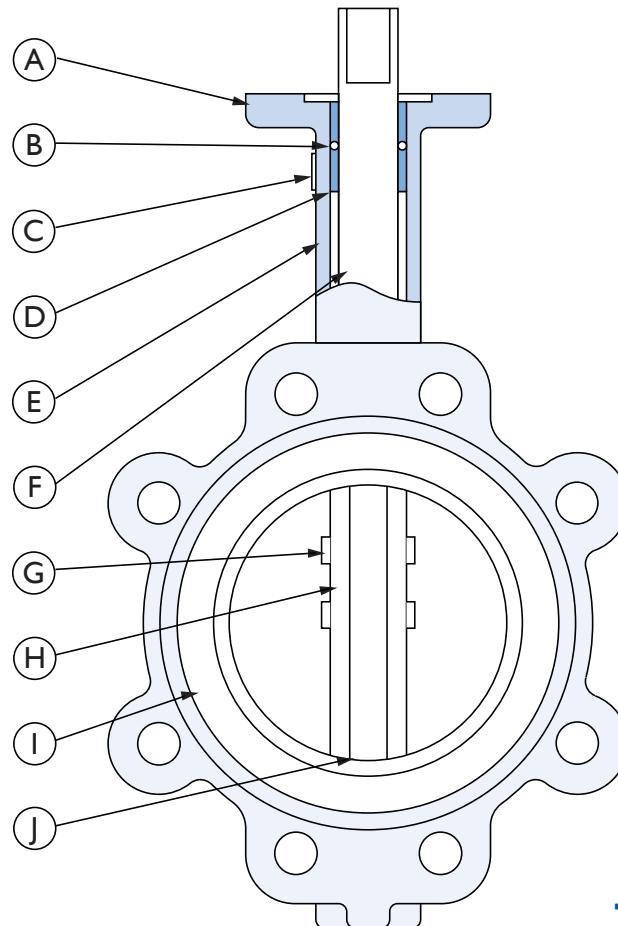

G Pinned Disc
The disc is attached to the shaft by pins that provide a solid mechanical connection.

H Disc
Disc edge is machined and polished 360° to assure leak-proof positive shut-off while minimizing operating torque.

I Phenolic Backed Seat
Provides additional support making the seat non-collapsible. 360° sealing protects components from media and provides the primary shaft seal. Flange gaskets are not required.

J Shaft Seal
The bi-directional shaft seal prevents external contamination of the stem area while providing a back-up for the primary shaft seal formed by the disc/seat interface.

The IFC series BII25W/L butterfly valve is available in sizes 2" thru 48", wafer or lug body design. These valves were designed to meet the stringent requirements for HVAC, Oil & Gas and Industrial applications, or wherever positive shut-off is required for liquids, gases and slurries.

Incorporating a 200 psig pressure rating for sizes 2" thru 12" and 150 psig pressure rating for sizes 14" thru 48" the IFC series BII25W/L valves are constructed with a cast iron

or ductile iron body and stainless steel shafts. The discs and seats are available in a wide range of materials to meet your specific application needs.

These valves are designed and manufactured for use with ANSI 125 or 150 class flanges and generally designed in accordance with API 609 (Except for the 16" to 20" face-to-face dimensions) and MSS-SP-67.

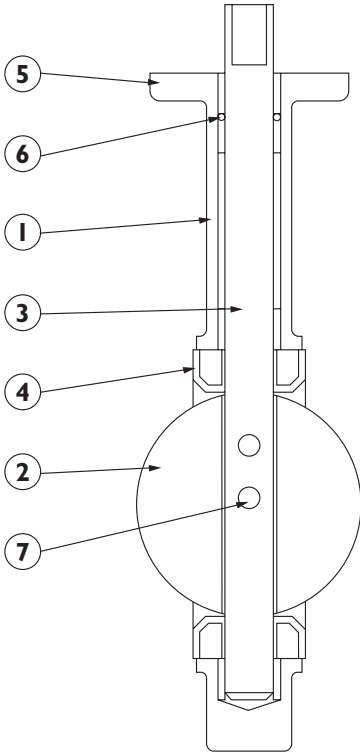

Material Specifications

Part No.	Part Name	Description	Material	Specifications
1	Body	Cast Iron Ductile Iron		ASTM A126-B ASTM A536 65-45-12
2	Disc	Ductile Iron Electrolytic Nickel Plated Aluminum Bronze Type 316 Stainless Steel		ASTM A536 65-45-12 ASTM B148 C954 ASTM A351-CF8M
3	Shaft	Type 416 Stainless Steel Type 316 Stainless Steel ²		ASTM A582 ASTM A276
4	Seat	Buna-N (-10°F to 180°F) EPDM (-10°F to 225°F) Viton 26B (-10°F to 275°F) Teflon lined EPDM (-10°F to 225°F)		
5	Bushings x 4	Teflon Impregnated Fiberglass Backed		
6	Seal	Buna-N O-Ring		
7	Pin	Type 316 Stainless Steel ^{4,5}		
	Key	Carbon Steel (Sizes 12" - 48")		
	Screws	18-8 Stainless Steel ¹ (Optional)		

- Notes:**
1. Dead end service screws are standard on lug body valves only.
 2. Valves with 316SS (Stainless Steel) discs are only available with 316SS shafts.
 3. Do not use EPDM when hydrocarbons are present.
 4. Valve sizes 6" and larger are equipped with two (2) pins.
 5. Valve sizes 4" and smaller are equipped with one (1) pin.

Standards of Construction

Component	Standard
General Design	API 609
Mounting Pad	ISO 5211
Laying Length	API 609, MSS SP-67, ISO 5752
Inspection and Testing	API 598

Upper Pressure Limits (Non-Shock)

Valve Size	M.A.W.P.
2" - 12" (50-300 mm)	200 psig (13.79 bars)
14" - 48" (350-1200 mm)	150 psig (10.34 bars)

Note: Valves rated for full vacuum service.

Velocity Limits

Fluids	30 ft/s (10 m/s)
Gases	200 ft/s (65 m/s)

Note: For greater velocities consult factory.

IFC BII25W/L Pressure Temperature Chart

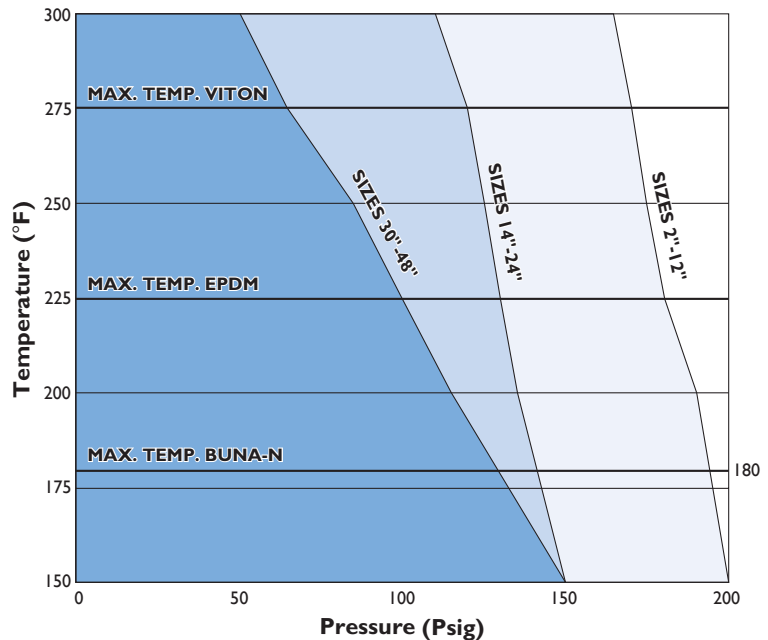

Cv Values (US-GPM @ 1 Psid)

Size in.	DISC POSITION (Degrees)								
	10 _i	20 _i	30 _i	40 _i	50 _i	60 _i	70 _i	80 _i	90 _i
2"	0.1	5	12	24	45	64	90	125	135
2 1/2"	0.2	8	20	37	65	89	144	204	220
3"	0.3	12	22	39	70	116	183	275	302
4"	0.5	17	36	78	139	230	364	546	600
5"	0.8	29	61	133	237	392	620	930	1022
6"	2	45	95	205	366	605	958	1437	1579
8"	3	89	188	408	727	1202	1903	2854	3136
10"	4	151	320	694	1237	2047	3240	4859	5340
12"	5	234	495	1072	1911	3162	5005	7507	8250
14"	6	338	715	1549	2761	4568	7230	10844	11917
16"	8	464	983	2130	3797	6282	9942	14913	16388
18"	11	615	1302	2822	5028	8320	13168	19752	21705
20"	14	791	1674	3628	6465	10698	16931	25396	27908
24"	22	1222	2587	5605	9989	16528	26157	39236	43116
30"	40	2036	4089	7461	11777	17578	26634	40975	58121
36"	60	3021	6063	11055	17449	26086	39731	60895	86375
42"	101	4738	9514	17361	27405	40903	61974	95344	135240
48"	134	6188	12426	22675	35794	53424	80945	124531	176640

Method Of Calculating Flow

Liquid Flow

$$Q_L = C_v \sqrt{\frac{\Delta P}{g}}$$

Q_L = flow rate of liquid (gal./min.)
 ΔP = differential pressure across the valve (psi)
 g = specific gravity of liquid: water = 1.000

Gas Flow

For non-critical flow ($\frac{\Delta P}{P_2} < 1.0$)

$$Q_g = 61 C_v \sqrt{\frac{P_2 \Delta P}{g}}$$

Q_g = flow rate of gas (CFH at STP)
 P_2 = outlet pressure (psia)
 g = specific gravity of gas: air = 1.000

Valve Seating Torque (In. - Lbs.)

Size in.	50 PSI ⁴		75 PSI ⁴		100 PSI ⁴		150 PSI		200 PSI	
	L	NL	L	NL	L	NL	L	NL	L	NL
2"	106	169	110	176	114	183	—	—	132	211
2 1/2"	153	245	159	255	165	265	—	—	191	306
3"	234	374	243	389	253	404	—	—	292	467
4"	346	554	361	577	375	600	—	—	433	693
5"	558	892	581	929	604	966	—	—	697	1115
6"	726	1234	756	1284	785	1335	—	—	907	1542
8"	1273	2164	1344	2285	1414	2403	—	—	1697	2885
10"	2143	3643	2263	3847	2380	4046	—	—	2857	4857
12"	3254	5206	3436	5497	3614	5782	—	—	4338	6941
14"	4383	6575	4810	7214	5236	7854	6088	9132	—	—
16"	5348	8022	6100	9150	6852	10278	8356	12534	—	—
18"	7167	10750	8175	12262	9182	13774	11198	16797	—	—
20"	9560	14340	10905	16357	12249	18374	14938	22407	—	—
24"	14944	22416	17046	25568	19147	28721	23350	35025	—	—
30"	28320	42480	28066	43498	30864	46296	33336	50004	—	—
36"	40624	60936	37982	59722	43480	65220	46528	69792	—	—
42"	69744	104616	66151	103467	74632	111948	79864	119796	—	—
48"	96648	145572	90157	142077	103840	155760	111112	166668	—	—

Notes: 1. "L" = Lubricated, "NL" = Non Lubricated.

2. Selection of actuator torque output must meet or exceed the maximum torque required by the valve.
3. Under certain conditions, hydrodynamic torque can exceed seating and unseating torques and must be considered in the selection of actuators.
4. Valve seating torques listed under 50, 75 and 100 PSI columns refer to valves with undercut discs.
Please consult factory for availability.

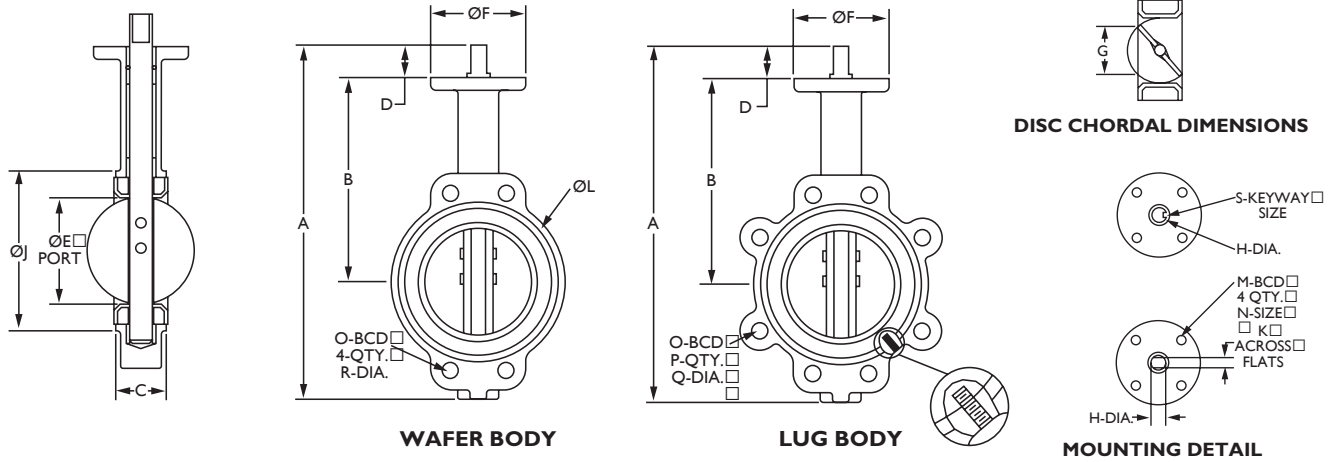

Valve Dimensions

Size	A	B	C	D	E	F	G	H	J	K	L	M	N	O	P	Q	R	S
in.	in.	in.	in.	in.	in.	in.	in.	in.	in.	in.	in.	in.	in.	in.		in.	in.	
(mm)	(mm)	(mm)	(mm)	(mm)	(mm)	(mm)	(mm)	(mm)	(mm)	(mm)	(mm)	(mm)	(mm)	(mm)		(mm)	(mm)	
2"	10.75	6.34	1.66	1.25	2.09	3.00	1.25	0.50	3.94	0.349	4.00	1.97	0.276	4.75	4	5/8"-11UNC	0.687	-
50	273	161	42	32	53	76	32	13	100	9	102	50	7	121			17	
2 1/2"	11.65	6.89	1.75	1.25	2.54	3.00	1.84	0.50	4.75	0.349	4.75	1.97	0.276	5.50	4	5/8"-11UNC	0.687	-
65	296	175	44	32	65	76	47	13	121	9	121	50	7	140			17	
3"	12.12	7.13	1.78	1.25	3.13	3.00	2.50	0.50	5.00	0.349	5.13	1.97	0.276	6.00	4	5/8"-11UNC	0.687	-
75	308	181	45	32	80	76	64	13	127	9	130	50	7	152			17	
4"	13.62	7.87	2.06	1.25	4.13	3.63	3.50	0.63	6.13	0.437	6.75	2.76	0.394	7.50	8	5/8"-11UNC	0.687	-
100	346	200	52	32	105	92	89	16	156	11	171	70	10	191			17	
5"	14.65	8.39	2.14	1.25	4.86	3.63	4.38	0.75	7.50	0.500	7.75	2.76	0.394	8.50	8	3/4"-10UNC	0.812	-
125	372	213	54	32	123	92	111	19	191	13	197	70	10	216			21	
6"	15.63	8.90	2.19	1.25	6.13	3.63	5.75	0.75	8.38	0.500	8.63	2.76	0.394	9.50	8	3/4"-10UNC	0.812	-
150	397	226	56	32	156	92	146	19	213	13	219	70	10	241			21	
8"	18.90	10.25	2.39	1.75	8.00	4.50	7.63	0.88	10.57	0.625	10.56	4.01	0.472	11.75	8	3/4"-10UNC	0.812	-
200	480	260	61	44	203	114	194	22	268	16	268	102	12	298			21	
10"	21.25	11.50	2.58	1.75	9.87	4.50	9.50	1.13	12.81	0.812	10.06	4.01	0.472	14.25	12	7/8"-9UNC	0.937	-
250	540	292	66	44	251	114	241	29	325	21	256	102	12	362			24	
12"	24.57	13.27	3.03	1.75	11.87	5.50	11.50	1.25	15.88	-	16.00	4.01	0.472	17.00	12	7/8"-9UNC	0.937	0.25 X 1.00
300	624	337	77	44	301	140	292	32	403		406	102	12	432			24	
14"	26.75	14.50	3.00	1.75	13.13	5.50	12.81	1.25	17.19	-	17.13	4.01	0.472	18.75	12	1"-8UNC	1.062	0.25 X 1.00
350	679	368	76	44	334	140	325	32	437		435	102	12	476			27	
16"	29.94	15.75	3.41	2.00	15.38	7.75	15.00	1.30	19.21	-	20.00	5.51	0.709	21.25	16	1"-8UNC	1.062	0.31 X 1.57
400	760	400	87	51	391	197	381	33	488		508	140	18	540			27	
18"	31.56	16.61	4.16	2.00	17.38	7.75	16.87	1.50	21.22	-	21.38	5.51	0.709	22.75	16	1 1/8"-7UNC	1.250	0.37 X 1.81
450	802	422	106	51	441	197	428	38	539		543	140	18	578			32	
20"	35.65	18.90	5.19	2.53	19.38	7.75	18.69	1.63	23.38	-	23.31	5.51	0.709	25.00	20	1 1/8"-7UNC	1.250	0.37 X 1.81
500	906	480	132	64	492	197	475	41	594		592	140	18	635			32	
24"	42.97	22.13	6.00	2.75	23.31	10.88	22.58	2.00	32.13	-	27.88	6.49	0.906	29.50	20	1 1/4"-7UNC	1.375	0.5 X 2.36
600	1091	562	152	70	592	276	574	51	816		708	165	23	749			35	

- Notes:**
- Quantity P and dimension Q refer to lug style. Dimension R refers to wafer style.
 - Dimension C is the installed dimension. Approximately 1/8" wider when relaxed.
 - Valves designed for installation between ASME B16.1 Class 125 and ASME B16.5 Class 150 flanges.
 - Gaskets are not required and should not be used.

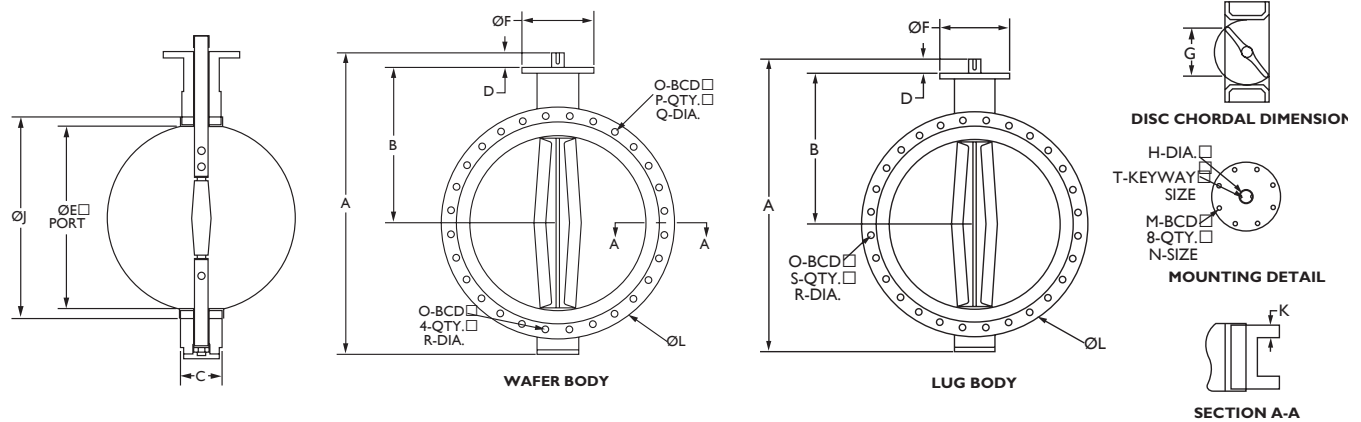

Valve Dimensions

Size	A	B	C	D	E	F	G	H	J	K	L	M	N	O	P	Q	R	S	T
in	in	in	in	in	in	in	in	in	in	in	in	in	in	in	in	in	in	in	in
(mm)	(mm)	(mm)	(mm)	(mm)	(mm)	(mm)	(mm)	(mm)	(mm)	(mm)	(mm)	(mm)	(mm)	(mm)	(mm)	(mm)	(mm)	(mm)	(mm)
30"	50.56	26.00	6.56	2.63	28.56	11.81	27.75	2.50	31.28	2.13	38.75	10.00	0.708	36.00	24	1.38	1 1/4"-7UNC-2B	28	0.71 X 2.48
750	1284	660	167	67	725	300	705	63	795	54	984	254	18	914	35				
36"	58.53	28.38	8.00	4.63	33.13	11.81	32.00	2.94	37.28	2.38	46.00	10.00	0.708	42.75	28	1.63	1 1/2"-6UNC-2B	32	0.79 X 3.94
900	1487	721	203	118	842	300	813	75	974	60	1168	254	18	1086	41				
42"	70.25	33.75	9.88	5.91	39.31	11.81	38.00	3.75	44.25	2.63	53.00	10.00	0.708	49.50	32	1.63	1 1/2"-6UNC-2B	36	0.98 X 5.51
1050	1785	857	251	150	998	300	965	95	1124	67	1346	254	18	1257	41				
48"	76.91	37.00	10.88	5.91	44.38	13.75	42.91	4.13	49.75	2.75	59.50	11.75	0.866	56.00	40	1.63	1 1/2"-6UNC-2B	44	1.10 X 5.51
1200	1954	940	276	150	1127	349	1090	105	1264	70	1511	298	22	1422	41				

- Notes:**
- Quantity S and dimension R refer to lug style. Quantity P and dimension Q refer to wafer style.
 - Dimension C is the installed dimension. Approximately 3/8" wider when relaxed.
 - Valves designed for installation between ASME B16.1 class 125 and ASME B16.47 series A class 150 flanges.
 - Gasket are not required and should not be used.

Manual Actuator Dimensions

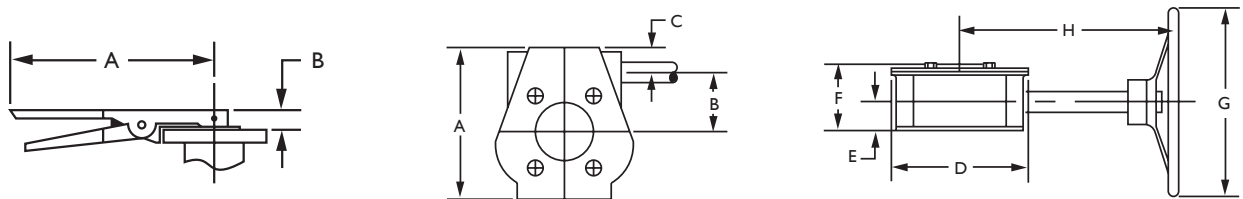

Lever

Valve Size	A	B	Weight
in	in	in	Lb.
(mm)	(mm)	(mm)	(Kg)
2" - 6"	10.0	1.0	3.0
50 - 150	252	24	1.4
8" - 12"	14.1	1.4	4.0
100 - 300	359	36	1.8

Notes:

It is recommended that handles be used thru 8" valve size for liquid or rated pressure service. 10" - 12" valves with handles should only be used on gas and low pressure applications.

Gear

Valve Size	Ratio	A	B	C	D	E	F	G	H	Weight
in		in	in	in	in	in	in	in	in	Lb.
(mm)		(mm)	(mm)	(mm)	(mm)	(mm)	(mm)	(mm)	(mm)	(Kg)
2" - 6"	24:1	5.0	1.7	1.1	4.1	1.6	2.6	6.0	7.6	10
50-150		127	45	28	105	41	66	152	193	4.5
8" - 10"	30:1	7.0	2.6	1.3	6.0	1.8	3.3	12.0	12.5	28
200-250		178	66	34	152	46	84	305	318	12.7
12" - 14"	50:1	7.8	3.0	1.5	6.6	2.0	3.5	12.0	12.5	33
300-350		198	76	38	170	51	89	305	318	15.0
16"	80:1	11.5	4.4	1.6	10.3	2.5	4.6	12.0	16.2	71
400		292	112	41	262	64	117	305	411	32.2
18" - 24"	290:1	12.3	4.7	2.8	10.8	2.9	6.3	12.0	13.4	118
450 - 600		313	120	73	274	75	162	305	342	53.5

Wafer Valve - Recommended Flange Bolt Lengths

Valve Size	Qty.	Bolt Size	Length Of Fasteners (L) Threaded Studs Bolts	
2"	4	5/8"-UNC	4 ³ / ₄ "	4"
2 ¹ / ₂ "	4	5/8"-UNC	5 ¹ / ₄ "	4 ¹ / ₄ "
3"	4	5/8"-UNC	5 ¹ / ₄ "	4 ¹ / ₂ "
4"	8	5/8"-UNC	5 ¹ / ₂ "	4 ³ / ₄ "
5"	8	3/4"-UNC	6"	5"
6"	8	3/4"-UNC	6"	5 ¹ / ₄ "
8"	8	3/4"-UNC	6 ¹ / ₂ "	5 ³ / ₄ "
10"	12	7/8"-UNC	7"	6"
12"	12	7/8"-UNC	7 ³ / ₄ "	6 ³ / ₄ "
14"	12	1"-UNC	8 ¹ / ₄ "	7"
16"	16	1"-UNC	8 ³ / ₄ "	7 ¹ / ₂ "
18"	16	1 ¹ / ₈ "-UNC	10"	8 ³ / ₄ "
20"	20	1 ¹ / ₈ "-UNC	11"	10"
24"	20	1 ¹ / ₄ "-UNC	12 ³ / ₄ "	11 ¹ / ₄ "

Note: Lengths are based on ANSI class 150 weld neck flanges per ASME B16.5.

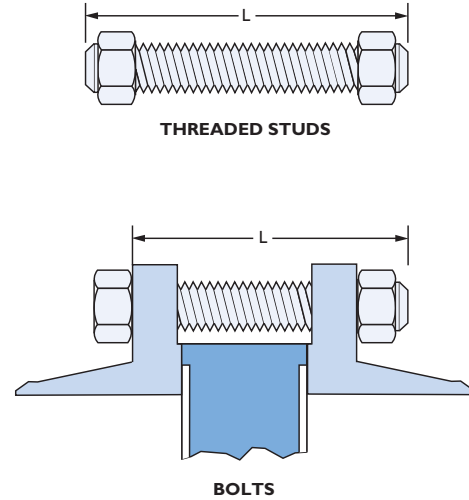

Lug Valve - Recommended Flange Bolt Lengths

Valve Size	Qty.	Bolt Size	Length Of Fasteners (L) Threaded Studs Bolts	
2"	4	5/8"-UNC	2 ¹ / ₄ "	1 ¹ / ₄ "
2 ¹ / ₂ "	4	5/8"-UNC	2 ¹ / ₄ "	1 ¹ / ₂ "
3"	4	5/8"-UNC	2 ¹ / ₂ "	1 ¹ / ₂ "
4"	8	5/8"-UNC	2 ¹ / ₂ "	1 ³ / ₄ "
5"	8	3/4"-UNC	2 ³ / ₄ "	1 ³ / ₄ "
6"	8	3/4"-UNC	2 ³ / ₄ "	1 ³ / ₄ "
8"	8	3/4"-UNC	3"	2"
10"	12	7/8"-UNC	3 ¹ / ₄ "	2 ¹ / ₄ "
12"	12	7/8"-UNC	3 ¹ / ₂ "	2 ¹ / ₂ "
14"	12	1"-UNC	3 ³ / ₄ "	2 ³ / ₄ "
16"	16	1"-UNC	4"	3"
18"	16	1 ¹ / ₈ "-UNC	4 ³ / ₄ "	3 ¹ / ₂ "
20"	20	1 ¹ / ₈ "-UNC	5 ¹ / ₄ "	4"
24"	20	1 ¹ / ₄ "-UNC	6"	4 ³ / ₄ "

Note: Lengths are based on ANSI class 150 weld neck flanges per ASME B16.5.

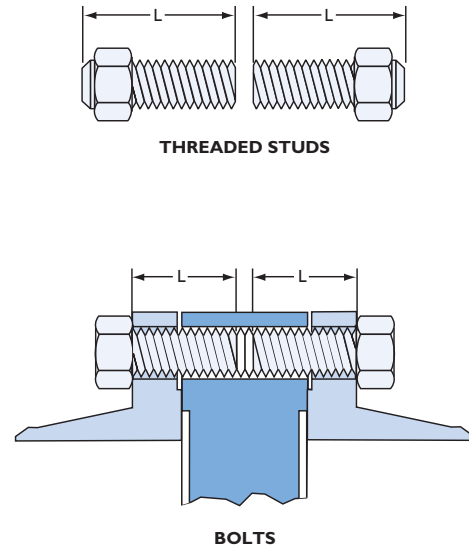

IFC Series I25WB/LB Valve Weights

Valve Size	2	2 ¹ / ₂	3	4	5	6	8	10	12	14	16	18	20	24
Wafer (Lb.)	6	7	10	13	18	20	32	42	70	95	117	165	275	440
Wafer (Kg.)	2.7	3.2	4.5	5.9	8.2	9.1	14.5	19.0	31.7	43.1	53.1	74.8	125	200
Lug (Lb.)	7	8	14	26	28	31	49	72	105	155	195	230	396	610
Lug (kg.)	3.2	3.6	6.3	11.8	12.7	14.1	22.2	32.7	47.6	70.3	88.4	104	180	277

Note: Valve weights refer to valve only.

A - Recommended, B - May Be Acceptable (Testing Recommended), N - Not Recommended																	
CORROSIVE MEDIA	PS	DISC MATERIALS				SEAT MATERIALS			CORROSIVE MEDIA	PS	DISC MATERIALS				SEAT MATERIALS		
		COND.	DI	AB	316	COND.	EPDM	BUNA-N			COND.	DI	AB	316	COND.	EPDM	BUNA-N
Acetaldehyde	L	<75 F	N	A	A		A	N	Lactic Acid	L		N	N	A		A	N
Acetone	L	<75 F	A	A	A	<130 F	B	N	Lime	S		N	A	A		A	B
Acetylene	G	<75 F	A	N	A	<160 F	A		Liquefied Petroleum Gas	G			A	A		N	A
Air	G		A	A	A		A	A	Malic Acid	S		N	B	A		N	A
Amines	L		B	B	A		B	N	Mercury	L		N	N	A		A	A
Amino Acids	L	<150 F	N	N	A		N	N	Methane	G			A	A		N	A
Ammonia, Anhydrous	G		B	N	A		A	B	Methyl Alcohol	L	<75 F	B	A	A		A	B
Ammonia Gas	G				A	<80 F	A	A	Methyl Bromide	G		B	A	A		N	B
Ammonia, Liquid	L			N	A		A	B	Methyl Chloride	G		N	A	A		N	N
Animal Fats	L		A	B	A		B	A	Naphtha	L		A	A	A		N	N
Arsenic Acid	S		N	N	A		A	A	Natural Gas	G			A	A		N	A
Beer-Breweries	L		N	N	A		A	A	Nitrogen - Gas	G		A	A	A		A	A
Beet Sugar Liquors	L		N	A	A		A	A	Nitrous Acid	L	<10%	N	N	B	<10%	N	N
Benzene	L		A	A	A		N	N	Octane	L		A	A	A		N	N
Benzol	L		A	A	A		N	N	Oil - Animal	L		A	B	A		N	A
Brine	L		N	B	A		A	A	Oil - Crude (sweet)	L		A	A	A		N	A
Bromine - Anhydrous	S		N	N	N		N	N	Oil - Crude (sour)	L		B	A	A		N	B
Bromine - Wet	L		N	N	N		N	N	Oil - Motor	L		A	A	A		N	A
Butane	G		B	A	A	<75 F	N	A	Oil - Peanut	L			B	A		N	A
Butter	L		N	N	A		B	A	Oil - Vegetable	L		N	B	A		B	A
Butylene (Gas)	G		A	A	A		N	N	Oxygen - Gas	G		A	A	A		A	B
Calcium Carbonate	S		N	N	A		A	A	Paint - Thinner/Remover	L			A	A		N	N
Calcium Chlorate	S		N	N	A		A	A	Pickling Solutions	L		N	N	N		N	N
Carbonated Water	L		N	N	A		A	A	Plating Solutions	L			N	N		A	N
Carbon Monoxide	G	<100 F	A	A	A	<100 F	A	A	Polyester Resins	L				A		N	N
Carbonic Acid	L		N	N	A		A	A	Potassium Bicarbonate	S			A	A		A	A
Cement	S		A	A	A		A	A	Potassium Chlorate	S	<100 F	B		A		A	B
Chlorine (Wet or Dry)	L		N	N	N		N	N	Potassium Nitrate	S	<75 F			A		A	A
Chlorox	L				A		A	B	Potassium Sulfide	S		N	N	A		B	N
Citric Acid	S	<100 F	N	B	A		A	A	Potassium Sulfite	S		N		B		A	A
Citrus Juices	L		N	B	A		A	A	Propylene	G				A		N	N
Coke Oven Gas	G		B	N	A		N	B	Pulp Stock	L	<4%	N	N	A	<4%	A	B
Diacetone Alcohol	L	<100 F	A	A	A		A	N	Resins	L		A	A	A		N	N
Dibutyl Amine	L				A		N	N	Sewage	L	<150 F	A	A	A		B	A
Dibutyl Ether	L				A		N	N	Silver Cyanide	S	<75 F	N	N	A	<120 F	A	N
Diesel Fuel	L		A	A	A		N	A	Sodium Bromide	S			N	N	N	N	N
Diethylamine	L			N	A		N	B	Sodium Carbonate	S		N	N	A		A	A
Dioxane	L		B	B	A		N	N	Sodium Chlorate	S		N	N	A		A	B
Dyes	L		A	A	A		N	N	Sodium Chloride	S		N	N	N	<130 F	A	A
Enamel	L		A	A	A		N		Sodium Nitrite	S		N	B	A		A	A
Ethane	G		A	A	A		N	A	Sodium Sulfate	S		N	A	A		A	A
Ethyl Alcohol	L		N	A	A	<180 F	A	A	Sodium Sulfite	S		N	N	A		A	A
Ethyl Benzene	L		A	A	A		N	N	Steam and Hot Water	L	<250 F	N	A	A	<250 F	A	N
Ethylene	G		A	A	A		N	A	Styrene	L		A	A	A		N	N
Ethylene Oxide	G	<10 F	B	N	A		N	N	Sugar Solutions	L		N	A	A		A	A
Fatty Acids	L		N	N	A	<180 F	N	A	Sulfur	S		N	N	A		A	N
Ferrous Chloride	S		N	N	N		A	A	Sulfuric Acid	L	<80%	N	N	B	<80%	N	N
Flue Gas	G		N	N	B		N	A	Sulfurous Acid	L		N	N	B		N	N
Gas-Natural	G		B	A	A		N	A	Transmission Fluid	L		A	A	A		N	A
Gasoline - Ethyl	L		B	A	A		N	N	Tributyl Phosphate	L				A		A	N
Gasoline - Regular	L		B	A	A	<85 F	N	A	Turpentine	L		N	A	A	<75 F	N	A
Glucose	L		A	A	A		A	A	Varnish	L		B	A	A		N	N
Glycerine	L	<100 F	B	A	A		A	A	Vinegar	L		N	N	A		A	B
Helium Gas	G				A		A	A	"Water, Carbonated"	L		N	N	A		A	A
Hydraulic Fluid (Pydraul)	L				A		N	N	"Water, Chilled"	L		N	A	A		A	A
Hydrocarbons (Aromatic)	L		A	N	A		N	N	"Water, Distilled"	L		N	N	A		A	A
Hydrogen Peroxide	L	<75 F	N	N	A		A	N	"Water, Salt, Sea"	L		N	A	A		A	A
Hydrogen Sulfide	G	<75 F	N	N	A		A	N	White Liquor	L		N	N	A		B	B
Iodine	L		N	N	N		N	N	Zinc Acetate	S		N	N	A		A	B
Jet Fuels (JP-1 to JP-6)	L		N	A	A	<80 F	N	A	Zinc Nitrate	S						A	
Kerosene	L	<75 F	A	A	A		N	A	Zinc sulfate	S		N	N	A		A	A

Notes: 1. PS stands for PHYSICAL STATE at room temperature;
S=Solid, L=Liquid, G=Gas
2. If uncertain please consult factory concerning valve compatibility.

No representation, warranty or guarantee of compatibility, expressed or implied, is made by this Selection Guide due to the complexity and almost infinite variations of mixtures, concentrations, temperatures and flow conditions possible in actual service. As a result, the end user must assume all responsibility for ultimate determination of value compatibility.

1.0 Piping and Flange Considerations

The IFC Series B1125W/L butterfly valves are to be installed between pipeline flanges that conform to ASME B16.1 Class 125 or ASME B16.5 Class 150. The use of slip-on or weld neck flanges has no effect on the pressure temperature rating of the valves.

2.0 Installation

Prior to installation, inspect valve and mating flanges to assure gasket surfaces are free of defects. Remove all foreign material such as weld spatter, oil, grease and dirt from the valve, flanges and pipeline. Do not mount valves between flanges having defective gasket surfaces.

- A. Check the distance between pipe flanges to ensure clearance for valve. Check piping for proper alignment.
- B. Place valve so that the disc has been positioned to a partially open position, with the disc edge about $\frac{1}{4}$ " to $\frac{3}{8}$ " from the face of the seat (approximately 10° open). In general, IFC recommends that the valve be installed with the stem in the vertical position and the actuator mounted directly above the valve.
- C. Check valve for proper alignment
 - On wafer valves, visually center the valve with respect to the flange faces.
 - Center lugged valves with the flange bolting. Never use lugged butterfly valves to align improperly positioned piping.
- D. Operate the valve to assure that no binding or interference exists.
- E. Tighten flange bolting evenly in a crisscross pattern. The flange joint is complete when there are no gaps between the valve body and the flange faces. Bolting should then be tightened sufficiently to prevent loosening.

The following additional procedures should be observed when installing butterfly valves between welding flanges.

- A. Assemble inlet and outlet flanges to the valve body and tighten.
- B. Align the flange/body/flange assembly to the pipe in which the valve is being installed.
- C. Tack weld flanges to the pipe.
- D. After tack welding, remove the bolts and valve from the pipe flanges and complete the welding of the valve installation flanges.

Important: To prevent seat damage, allow the flanges to cool before final installation of the butterfly valve.

3.0 Valve Removal

Warning: Pipeline pressure can cause personal injury or equipment damage. Relieve pipeline pressure before loosening flange bolts and disable/lock valve actuator before valve removal.

- A. Discontinue pipeline flow, relieve pressure where the valve is located in the pipeline and close the valve.
- B. If the actuator is powered, disconnect and lock out the power to prevent accidental operation of the actuator.
- C. Support the valve and remove the mounting bolts or studs.
- D. Carefully lift the valve from the pipeline.

4.0 Maintenance

The many IFC features minimize wear and maintenance requirements. IFC Series B1125W/L valves require no periodic maintenance or lubrication. IFC does recommend the following actions on a monthly basis:

- A. Operate the valve from full open to full close to assure operability.
- B. Check bolting for evidence of loosening and correct as required.
- C. Inspect flange faces and valve stem for signs of leakage. Tighten packing gland if necessary.
- D. Check piping and related accessories (i.e. actuator) for looseness, corrosion or defects. Correct as required.

5.0 Warranty

All products are warranted to be free of defects in material and workmanship for a period of one year from the date of shipment, subject to the limitations below: If the purchaser believes a product defective, the purchaser shall: (a) Notify the manufacturer, state the alleged defect and request permission to return the product. (b) If permission is given, return the product with transportation prepaid. If the product is accepted for return and found to be defective, the manufacturer will, at its discretion, either repair or replace the product, f.o.b. factory, within 60 days of receipt, or refund the purchase price.

Other than to repair, replace or refund described above, the purchaser agrees that the manufacturer shall not be liable for any losses, costs, expenses or damages of any kind arising out of the product, its use, installation or replacement, labeling, instructions, information or technical data of any kind, description of product use, sample or model, warnings or lack of foregoing. No other warranties, written or oral, expressed or implied, including the warranties of fitness for a particular purpose and merchantability, are made or authorized.

No affirmation of fact, promise, description of product use or sample or model shall create any warranty from the manufacturer, unless signed by the president. These products are not manufactured, sold or intended for personal, family or household purposes.

